



TECHNOLOGICAL LINES & EQUIPMENT FOR MANUFACTURE OF

- **CHOCOLATE PRODUCTS**
- **KETCHUP**
- **MAYONNAISE**
- **FINE PASTA PRODUCTS**

ПИМ

ЛИНИЯ ЗА ПРОИЗВОДСТВО НА ШОКОЛАДОВИ ИЗДЕЛИЯ (сухи пасти, вафли, бисквити, тунгвани ядки, смокини и др.)

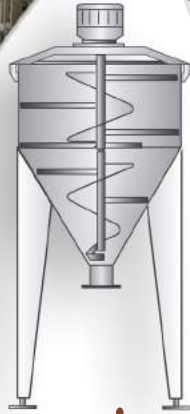

Съд буферен
Buffer container

Съд за прахообразни материали
Container for powder substances

Technical parameters

Обем/ Volume	2000 l
Габаритни размери/Overall dimensions:	
- диаметър/ Diametre	1720 mm
- височина/ Height	2900 mm
Инсталирана мощност/ Inst.Power	2.2 kW

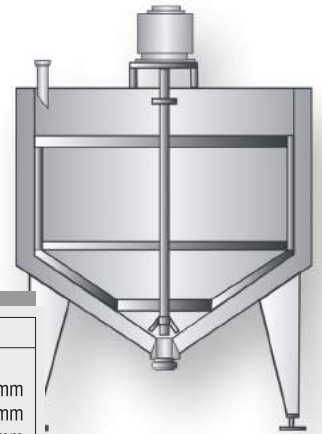

Technical parameters

Обем/ Volume	500 l
Габаритни размери/Overall dimensions:	
- диаметър/ Diametre	1000 mm
- ширина/ Width	1080 mm
- височина/ Height	2420 mm
Инсталирана мощност/ Inst.Power	1.5 kW

Смесител за масло
Butter mixer

Technical parameters

Обем/ Volume	2000 l
Габаритни размери/Overall dimensions:	
- диаметър/ Diametre	1720 mm
- височина/ Height	2200 mm
Инсталирана мощност/ Inst.Power	2.2 kW



Машина за шоколадов кувертюж
Machine for chocolate couverture

Technical parameters

Обем/ Volume	2000 l
Габаритни размери/ Overall dimensions:	
- диаметър/ Diametre	1640 mm
- ширина/ Width	2300 mm
- височина/ Height	2900 mm
Обща инстал. мощност/ Total Inst.Power	25 kW



Съд за хомогенизиране на смеси
Turbomixer

Technical parameters

Обем/ Volume	100 l	300 l
Габаритни размери/Overall dimensions:		
- диаметър/ Diametre	500 mm	734 mm
- ширина/ Width	540 mm	780 mm
Обща инстал.мощност/ Total Inst.Power	3 kW	6.5/8 kW



CHOCOLATE PRODUCT PRODUCTION LINE
(chocolate cakes, waffles, biscuits,
coated nuts, figs etc.)



Машини за обмазване на шоколадови изделия
Machines for daubing chocolate products



Technical parameters

Производителност/Capacity	16 блата/16 pieces/min
Обем на ваната/Capacity of the tub	129 l
Габаритни размери/Dimensions, mm	
- дължина/length	1220 mm
- ширина/width	1200 mm
- височина/height	1850 mm
Дължина на гитер лентата/Length of the gitter band	2600 mm
Ширина на гитер лентата/ Width of the gitter band	800 mm
Инст. мощност/Installed power	4,5 kW



Машина за тункване на шоколадови изделия
Coating machine

Technical parameters

Производителност/Capacity	24 блата/24 pieces/min
Обем на ваната/Capacity of the tub	129 l
Габаритни размери/Dimensions, mm	
- дължина/length	2400 mm
- ширина/width	1200 mm
- височина/height	1850 mm
Дължина на гитер лентата/Length of the gitter band	3650 mm
Ширина на гитер лентата/ Width of the gitter band	800 mm
Инст. мощност/Installed power	3,5 kW



Машина за печене на вафлени кори
Wafer sheets baking machine

Technical parameters

Изпичащи клещи/ Baking tongs	40 бр./pcs
Производителност/Capacity	850 бр./ч
Габаритни размери/Dimensions mm	
- дължина/length	8700 mm
- широчина/width	1700 mm
- височина/height	2000 mm
Обща инст. мощност/Total inst. power	132 kW



*Машина за рязане на вафли - пневматична
Waffle cutting machine - pneumatic*

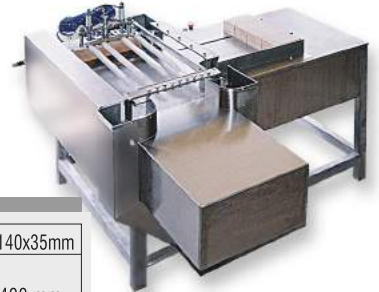

Technical parameters

За вафли с размер/For waffles size	115x35mm, 140x35mm
Габаритни размери/Dimensions, mm	
- дължина/length	1400 mm
- ширина/width	1950 mm
- височина/height	1170 mm
Инст. мощност/Installed power	0,1 kW

*Лентов охладителен тунел
Belt cooling tunnel*



Technical parameters

Условна дължина/Conditional length	10 m; 20 m
Габаритни размери/Overall dimensions	
- широчина/width	1650 mm
- височина/height	1300 mm
Инст. мощност/Inst. power	8 kW; 16 kW



*Транспортър шнеков за сухи смеси
Worm transporter for dry mixtures*

- Допълнителни съоръжения/ Additional equipment:
- Мелница за ядки/ Nut grinder;
 - Мелница за вафлени кори/ Wafer grinder.

**ЛИНИЯ ЗА ПРОИЗВОДСТВО НА МАЙОНЕЗА И
ДРУГИ ВИДОВЕ СОСОВЕ
LINE FOR PRODUCTION OF MAYONESE AND
OTHER SAUCES**



Съд под вакуум с бъркалка
Vacuum container with ladle

Съд за готов продукт
Container for the ready-made product

Съд буферен
Buffer container

Дозираща машина
Dosing machine

Помпа винтова
Screw-pump

Вакуум-помпа
Vacuum-pump

Помпа винтова
Screw-pump

Хомогенизатор
Homogenizer

Technical parameters

Производителност/Capacity	1000 kg/shift (кг/смяна)
Габаритни размери/Overall dimensions	3600/1200/2300 mm
Необходима работна площ/ Working area required for the personnel	30 m ²
Обща инст. мощност/Total Inst. Power	10 kW

*Деаератор поточен
Line deaerator*



*Резервоар с бъркалка
Container with mixer*



*Съд буферен
Buffer container*



*Технологична линия
Tehnological line*

Technical parameters

Производителност/Capacity	1000 kg/h (кг/час)
Габаритни размери/Overall dimensions	6500/9000 mm
Необходима работна площ/ Working area required for the personnel	60 m ²
Обща инстал. мощност/Total Inst. Power	16 kW

*Съд с изолация
Container with isolation*



*Погревател с пастъоризатор
Heater with pasteurizer*

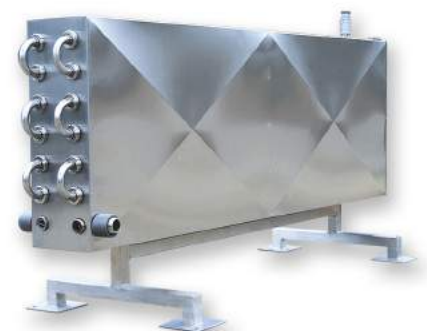

**ЛИНИЯ И ОБОРУДВАНЕ ЗА ПРОИЗВОДСТВО
НА МАКАРОНЕНИ ИЗДЕЛИЯ
LINE AND EQUIPMENT FOR MANUFACTURE
OF FINE PASTA PRODUCTS**



*Машина за разбъркване МБ 250
Mixing machine*



Technical parameters

Производителност/ Capacity	150-200 kg/h (кг/час)
Габаритни размери/ Overall dimensions	1300/600/1030 mm
Вместимост/ Volume	250 l
Инсталирана мощност/ Inst. Power	1.5 kW
Маса/ Weight	120 kg

*Машина за пресоване на макаронени изделия
Extruder for pasta*

Technical parameters

Производителност/ Capacity	100 kg/h (кг/час)
Габаритни размери/ Overall dimensions	1400/700/1700 mm
Диаметър на матрицата/ Matrix diameter	140 mm
Потребление на вода/ Water consumption	70 l/h
Инсталирана мощност/ Inst. Power	7 kW
Маса/ Weight	450 kg



*Сушилня за макаронени изделия
Drying Oven*

Technical parameters

Производителност/ Capacity	400 kg/cycle (кг/цикъл)
Габаритни размери/ Overall dimensions	3500/1455/2400 mm
Вместимост/ Volume	4 колички+104 скари 4 carriages+104 grates
Маса/ Weight	530 kg





ПИМ ООД

бул. "Васил Левски" 6

6300 Хасково

тел.: 038/ 664601, факс: 038/ 664604

e-mail: pimltd@haskovo.spnet.net

PIM Ltd.

6, "Vassil Levski" Blvd.

6300 Haskovo, Bulgaria

tel.: ++359 38 664601, fax: ++359 38 664604

e-mail: pimltd@haskovo.spnet.net

ОБОРУДВАНЕ за ПРОИЗВОДСТВО на

- шоколадови изделия
- кетчуп
- майонеза
- макаронени изделия



www.pimbg.com